

INSTRUCTION MANUAL

M E T E R I N G P U M P S

LINC84T-17, 18 & 20 Series Chemical Metering Pump
Pneumatic Plunger



METERING PUMPS

T A B L E O F C O N T E N T

Contents - 84T-17, -18 & -20 Pump Manual	Page
General Specifications	4
Selection Chart	4
Ordering Chart	5
Scope Of This Manual	6
Installation	6
Maintenance	6
Removing the Pump from Service	6
Timer	7
Relay	7
Suction Check Valve	8
Discharge Check Valve	8
Piston/Plunger	9
Plunger Seal	9
Reassembling The Pump	9
How to Determine Supply Pressure	10
Assembly Drawings & Parts Lists	
Figure 1, 84-T Assembly Drawing	12
Pump Assembly Parts List: 84-T	13, 14, & 15
Figure 2, "T" Series Timer	16
Figure 3, Double Acting Relay	17
Figure 4, Two Seal Single Acting Relay)	18
Figure 5, Single Acting Relay	19
Figure 6, Discharge Check Valve	20
Figure 7, Suction Check Valve	21
Figure 8, Suction Check Valve	21
LINC Chemical Pump Gas Consumption Chart	22

METERING PUMPS

P N E U M A T I C P L U N G E R

General Specifications: 84T-17, 18 & 20 Series Pneumatic, Plunger Metering Pumps

Wetted Parts:

Pump Body:	316 ss
Plunger:	17-4 PH ss, or Ceramic Coated
Plunger Seal:	Refer to Ordering Chart

Check Valves :

Body:	316 ss
Ball:	440C ss or Carbide
Spring - Discharge:	316 ss
Seat:	TFE

Pneumatic Section:

Piston Housing:	303 ss
Timer:	316 ss
Relay:	316 ss

Plunger Sizes: 1" to 2 1/4" plunger diameters

Pressure: To 10,000 psi, maximum

Optional Materials: 316 ss, Hastelloy, Monel, & Titanium

The LINC 84T-17, 18 & 20 Series: Pneumatic, Plunger-Type Metering Pump Selection Chart

Model Number	Plunger Diameter	Piston Diameter	Max. Rate Gal/Hr	Max. Rate Liter/Hr	Min. Rate Gal/Hr	Min. Rate Liter/Hr	Max. Pressure psi	Max. Pressure bar	Theoretical Amp. Ratio	Strokes Per Minute	Volume Per Stroke	Stroke Length
1" Plunger with Timer/Relay												
84T-17-x6	1"	6"	8.1	30.7	0.2	0.8	5,000	345	36:1	4 - 35	19.3 cc	1 1/2"
84T-17-x8	1"	8"	8.1	30.7	0.2	0.8	10,000	690	64:1	4 - 35	19.3 cc	1 1/2"
1 1/2" Plunger with Timer/Relay												
84T-18-x4	1 1/2"	4"	22	83	0.9	3.5	600	41	7:1	4 - 40	36.1 cc	1 1/4"
84T-18-x6	1 1/2"	6"	22	83	0.9	3.5	1,950	134	16:1	4 - 40	36.1 cc	1 1/4"
84T-18-x8	1 1/2"	8"	22	83	0.9	3.5	3,450	238	28:1	4 - 40	36.1 cc	1 1/4"
2 1/4" Plunger with Timer/Relay												
84T-20-x6	2 1/4"	6"	90	341	2.1	7.8	900	62	7:1	4 - 35	162 cc	2 1/2"
84T-20-x8	2 1/4"	8"	90	341	2.1	7.8	1,800	124	12:1	4 - 35	162 cc	2 1/2"
84T-20-x10	2 1/4"	10"	90	341	2.1	7.8	2,700	186	19:1	4 - 35	162 cc	2 1/2"

Notes:

- Maximum rates are based on maximum strokes per minute per pump.
- Minimum rates are calculated as follows:
1" plunger pumps are 1/4" stroke length and a minimum of 4 strokes per minute.
1-1/2" and 2-1/4" plunger pumps are 1/2" stroke length and a minimum of 4 strokes per minute.
- The timer supply pressure is 20 to 100 psi.
- The relay supply pressure range is 50 to 180 psi.
- When creating a Model Number using the Ordering Chart, the "x" in the Model Number column above will be replaced by a single digit representing the plunger seal selection. The plunger seal is shown in the Ordering Chart.

METERING PUMPS

P N E U M A T I C P L U N G E R

Ordering Chart: LINC 84T-17, 18 & 20 Series Pneumatic Plunger Metering Pump

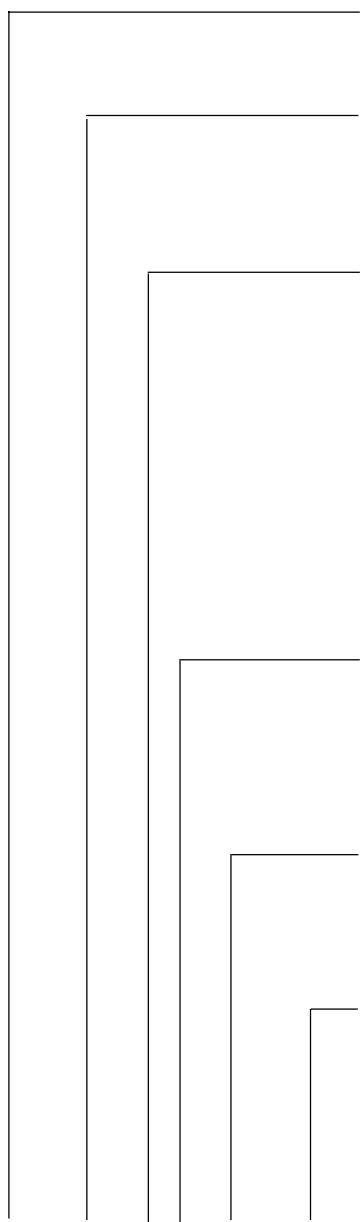

Series:

84T - Pneumatic, plunger type metering pump

Plunger Diameter:

- 17 - 1" plunger diameter
- 18 - 1-1/2" plunger diameter
- 20 - 2-1/4" plunger diameter

Plunger Seal:

- 1 - Packing mechanical seal - Fluorocarbon, wetted o-rings - Fluorocarbon
- 2 - Packing mechanical seal - Fluoromyte, wetted o-rings - TFE
- 3 - Packing mechanical seal - Nitrile, wetted o-rings - Nitrile
- 4 - Packing mechanical seal - TFE/Graphite, wetted o-rings - TFE
- 5 - Specify your requirements
- 6 - Packing mechanical seal - Ultra High Molecular Weight Polyethylene, wetted o-rings - TFE
- 7 - O-rings packing seal - Fluorocarbon, wetted o-rings - Fluorocarbon
- 8 - O-rings packing seal - Nitrile, wetted o-rings - Nitrile
- 9 - O-rings packing seal - Kalrez, wetted o-rings - Kalrez

Piston Size:

- 4 - 4" piston diameter
- 6 - 6" piston diameter
- 8 - 8" piston diameter
- 10 - 10" piston diameter

Other:

- 5 - Specify your requirements
- 9 - All 316 ss pump/timer/relay (when required)

Option Number:

- () - If the pump does not require any special modifications, Omit "Option Number" from the part number. If the pump does require special modifications, use "5" for "Other", and "(x)" for the Option Number when placing an order. The factory will replace the "(x)" with a unique option code at the time of pump production. Example 84T-17-46-5(7).

LINC 84T-____-____-____ ()

Example: LINC 84T-17-46-6 Pneumatic Metering Pump

METERING PUMPS

PNEUMATIC PLUNGER

Scope Of This Manual:

This manual describes and provides instructions and parts list for the LINC84T-17, 84T-18 and the 84T-20 Series Chemical Metering Pump. These pumps are pneumatically operated plunger pumps.

Installation:

These pumps require a flooded suction and must be located lower than the chemical supply tank. Vertical installation of the piston housing is required.

1. Connect the suction line through a filter or strainer to the suction check valve (fig. 1, item 22).
2. Connect the discharge line from the discharge check valve to the desired location (fig. 1, item 21).

Note: An in-line check valve at the point of injection is recommended to prevent back blow to the pump during shutdown or servicing.

3. Connect supply pressure to the timer and both relays (fig. 1, item 1). Air is the recommended supply; however, any dry filtered gas may be used. The supplies to the timer and relay must be separate. Two filter-regulators are required, one to control the supply pressure to the timer and another to control the supply pressure to the relay. The supply pressure to the timer should be between 20 psig and 100 psig. The supply pressure to

the relay should be between 50 psig and 180 psig.

4. Using the regulator that feeds the supply to the relay, set the supply pressure to overcome the discharge pressure of the pump. See "How To Determine Supply Pressure" in this section of the manual.
5. The timer can be set to stroke the pump between 4 strokes/minute and the maximum rate for the particular pump being used. See the selection chart in this section of the manual.
6. The stroke length is adjusted by rotating the stroke adjustment screw. Assure that the control knob on the timer is set so that the pump will not stroke over the maximum strokes per minute. Slowly increase the supply to the timer, using the regulator that feeds the timer, until the pump begins to stroke smoothly. This pressure should be equal to or slightly less than the supply to the relays.
7. To prime the pump, loosen the bleed screw (fig. 1, item 23). Allow the liquid (chemical) to flow into the pump chamber, venting the trapped air or gas. Tighten the bleed screw. Start the pump and run for a minimum of one minute. Open the bleed screw again and evacuate all the remaining air or gas from the pump chamber.
8. Using a rate gauge, set the desired pumping rate by adjusting the timer knob and stroke adjustment screw. The timer can be set to stroke the pump from 4 strokes/minute to the maximum rate for the particular pump being used. The stroke length is adjusted by rotating the stroke adjustment screw on top of the piston housing (fig. 1, item 6). Loosen the jam nut and adjust the stroke adjustment screw as necessary (fig. 1, item 7). Lock down the jam nut after any adjustments are made.

Note: The minimum stroke on the 84T-17 is 1/4" and 1/2" on the 84T-18 and 84T-20.

Maintenance:

Refer to all sectional drawing and parts list in this manual. All repairs should be performed in a clean environment.

The following steps must be taken before proceeding with any maintenance operations:

Removing the Pump from Service:

1. Rotate the control knob on the timer to the "O" position.
2. Disconnect the supply pressure from the timer and relay.
3. Close the upstream and downstream valves on the chemical lines.

METERING PUMPS

PNEUMATIC PLUNGER

4. Open the bleed screw to release the pressure in the pump.
5. Disconnect the suction and discharge lines from the check valves.

Timer, Figure 1, item 1 & Figure 2:

1. Disconnect the supply pressure from the timer.
2. Rotate the timer counter clockwise on the pipe nipple that connects it to the relays until the timer is vertical with the supply pressure port pointing down.
3. Loosen and remove the two screws from the timer (fig. 2, item 1).
4. Separate the three timer sections and discard the seal, diaphragm and the disc (fig. 2, items 4, 6 & 15). Be careful not to lose the small disc spring (fig. 2, item 16). Note the orientation of the diaphragm as it is removed.
5. Loosen the set screw on the knob (fig. 2, item 11). Remove the knob and knob spring (fig. 2, item 9).
6. Unscrew the adjustment screw (fig. 2, item 10) from the front body (fig. 2, item 13). Remove and discard the o-ring (fig. 2, item 12).
7. Reassemble the timer in reverse order of the above steps using new rubber parts. Lubricate the adjustment screw threads and its o-ring. No other lubrication is required.
8. After installing the adjustment screw, turn it in by hand, without the knob installed until it lightly seats. During this operation do not over tighten the adjustment screw into its seat. Apply supply pressure to the timer and unscrew the adjustment screw slowly until the pump starts to run. Trial and error will be necessary to determine the proper orientation of the knob on the adjustment screw. Once the proper orientation is determined, reinstall the knob spring and knob.

Relays:

Note: If your pump was manufactured prior to 9-01-2001, it was manufactured with a "Double-Acting-Relay", use Relay Procedure "A" to service this type. If your pump was manufactured after 09-01-2001, it was manufactured with two "Single-Acting-Relays", use Relay Procedure "B" to service this type.

Relay Procedure A: (DOUBLE ACTING)

Figure 1, item 1 & Figure 3:

1. Disconnect the supply pressure from the relay.
2. Disconnect the tubing (fig. 1, items 2 & 3) between the relay and center ring (fig. 1, item 12).
3. Unscrew the relay from the nipple that connect it to the piston housing (fig. 1, item 8)

4. If the relay is not functioning properly and/or is leaking, the parts in the repair kit #24284 should be replaced (fig. 3, item 6, 14, 15, & 16). This repair kit consists of three o-rings, a piston seal, spring and two poppets.
5. Remove the four socket head screws that hold the lid on the relay (fig. 3, items 13 & 1). Also remove the four socket head screws that hold the three body sections together (fig. 3, item 10). Note the location of all ports so that the location can be the same when the unit is reassembled. Separate the body parts and the lid. Remove the lock nut which will allow each individual part to be inspected (fig. 3, item 3). Replace the old parts with the parts from the new repair kit and reassemble. Special care should be taken to see that each part especially the piston spacer and the seal spacer is put back into the same location when reassembling (fig. 3, items 5 & 7).
6. To test the relay prior to reassembly, connect the supply to the port marked "IN". Supply should be routed to the port marked "OUT 1" with no leakage to the port marked "E1". Connect the pressure to 1/8" NPT port in the lid. Supply should be routed to the port marked "OUT 2" with no leakage to

METERING PUMPS

P N E U M A T I C P L U N G E R

port marked "E2".

7. Reinstall the relay on the nipple on the pump piston housing. Making sure that the nipple is connected to the proper port on the relay, port marked "OUT 2", and that the port marked "OUT 1" is connected to the tubing that goes between the relay and the center ring below the piston housing.

Relay Procedure "B": (TWO SINGLE ACTING)

Figure 1, item 1 & Fig. 4 & 5:

1. Disconnect the supply pressure from the relay.
2. Disconnect the timer/relay assembly from the top and bottom of the pump piston housing. (fig. 1, items 8 & 12).
3. Remove both relays from all fittings in the assembly for inspection.
4. If either or both relays are not functioning properly, replace the old parts with new one included in the repair kits # 25182 & #25418. This repair kit contains o-rings, piston seals, spring and poppet.
5. Remove the four capscrews that hold the lid on the relay (fig. 4, item 10 and/or fig. 5, item 10).

Note the location of all ports so that the correct orientation can be reestablished when the relay is reassembled.

Separate the body parts and the lid. Remove the lock nut which will allow each individual part to be inspected (fig. 4 & 5, item 3). Replace the old parts with new ones from the repair kit, and reassemble the relay.

6. To test the relays prior to assembling them to the pump, follow these steps. Put a 1/4" pipe plug into port #2. Connect supply pressure to port #1. There should be no leakage to port #3. Leaving supply pressure on port #1, and removing the pipe plug from port #2. Apply supply pressure also to port #4 (1/8" NPT) in the lid. After a short blast of air as the poppet shifts, there should be no leakage out of port #2.
7. Connect the relays with the timer/relay assembly to the pump as they were prior to disassembly. Make sure that the longer of the two relays is installed on the top of the pump piston housing with the shorter relay on the bottom. Also make sure that the fittings are connected to the proper ports and installed according to the assembly. (fig. 1)

Suction Check Valve, Figure 1, item 22 & Figure 7:

1. Disconnect the piping from the check valve.
2. Unscrew the check valve body from the pump (fig. 7, item 1).
3. Remove and discard the o-rings (fig. 7, items 2 & 4).
4. Inspect the ball for damage (fig. 4, item 3). Replace if necessary. Reassemble the check valve using new o-ring. If the seat o-ring is Teflon, install it onto the check valve body (fig. 7, item 1) and "peen" the ball into the seat to ensure proper sealing.

Note: The suction check valve on Models 84-18 & 84-20 are metal seats; therefore, do not use an o-ring.

5. Install the repaired suction check valve into the pump body. Tighten securely.

Discharge Check Valve, Two-Piece, Figure 1, item 21 & Figure 6:

1. Separate the two halves of the check valve (fig. 6, items 4 & 1).
2. Replace the o-rings, ball and spring as required (fig. 6, items 2, 3, 5 & 6). The Teflon o-ring may be removed, turned around and reused if a new o-ring is not available (fig. 6, item 2). During this procedure, extreme care should be

METERING PUMPS

PNEUMATIC PLUNGER

exercised. The ball should be "peened" on the Teflon seat to ensure proper sealing (fig. 6, items 1, 5 & 2).

3. Ensure that the proper flow direction, as marked on the valve body is observed when installing or replacing this check valve.
4. Install repaired discharge check valve into the pump body. Tighten securely.

Piston/Plunger, Figure 1, item 9, 27, 28, 29 & 30:

1. Secure the pump body in a vise.
2. Remove the tubing (fig. 1, items 2 & 3) between the relay and the center ring (fig. 1, item 12).
3. Remove the piston housing screws (fig. 1, item 13). Grasp the piston housing and pull up to remove (fig. 1, item 8) and pull up to remove.
4. Grasp the piston (fig. 1, item 9) and pull away from the pump body assembly to remove. Inspect the plunger for wear, especially longitudinal grooves. Replace the plunger if necessary.

Note: The piston and plunger on the Model 84T-17 is a single piece and must be replaced as a unit. On Models 84T-18 & 84T-20 the plunger is a separate piece. To remove the plunger (fig. 1, item 30) from the piston (fig. 1, item 9) loosen the set screws (fig. 1, item 27) and twist out the piston cap (fig. 1, item

28). The plunger will now screw out of the piston. Inspect the piston u-cups and piston-plunger o-ring (fig. 1, items 10 & 29). Replace if necessary.

Plunger Seal, Figure 1, item 18 & 19:

1. With a pipe or strap wrench, separate the three sections of the pump main body assembly (fig. 1, item 11, 17 & 20).
2. Carefully remove the two plunger seals (fig. 1, item 19) and the two plunger seal backups (fig. 1, item 18). One set will be in the center housing adapter (fig. 1, item 11) and the other set will be in the lower body (fig. 1, item 20 or 31). Inspect for wear or deterioration from being attacked by the chemical the pump is pumping.
3. Replace the plunger seal.

Note: The expander ring side of the plunger seal must be facing the pressure. This means that the lower seal will have the expander ring side down toward the suction check valve and the upper seal will have the expander ring side up toward the piston housing. If needed, also replace the plunger seal backup. Extreme care should be taken not to scratch or distort these parts.

4. Reassemble the three sections of the pump body assembly. Tighten securely.

Reassemble the Pump:

1. Lubricate the piston u-cup and piston assembly with light oil to protect against possible damage during assembly.
2. Reassemble the piston/plunger assembly and install into the pump body assembly. See Figure 1 for correct assembly.
3. Replace the piston housing and secure with the piston housing screws.
4. Assure that the piston housing is oriented so that the tubing will reconnect properly to the timer/relay assembly.
5. If the bleed screw has been removed, install and tighten securely.

Plunger and Plunger Seal Lubrication:

1. Remove the plug from the pump body (fig. 1, item 24).
2. Add silicone base lubricant (Dow Corning DC-7, part #10354) or equal into the port where the plug was removed. Approximately 1 oz. will be required for each refill. Replace the plug.
3. Silicone lubricant should be added every 4 - 6 weeks depending upon operation conditions.

Note: Do not use a grease gun or any metal tool to insert the lubricant into the pump to prevent damage to the plunger or plunger seal.

METERING PUMPS

P N E U M A T I C P L U N G E R

IMPORTANT: How To Determine Supply Pressure:

The theoretical amplification ratio shown in the Selection Chart of this manual is the area of the piston divided by the area of the plunger. This amplification ration is used to determine how much gas supply pressure is required to enable the pump to generate the required liquid discharge pressure. The theoretical gas supply pressure required to generate a specific liquid discharge pressure is calculated by dividing the required liquid pressure by the amplification ratio. However, the amplification ratio is a theoretical number and in an actual application, other factors such as friction and stroke rate require that a higher gas supply pressure be used.

To determine the approximate gas supply pressure to the relay, add 30 PSI (up to 40 PSI for higher pump stroke rates) to the calculated theoretical gas supply pressure.

For example, if it is required to generate 6000 PSI with an 84T-17-X8 pump, follow the procedure below to determine the approximate gas supply pressure that must be used.

The required liquid discharge pressure divided by the theoretical amplification ratio = 6000 PSI divided by 64 = 94 PSI. Now add 30 PSI to the theoretical 94 PSI. Therefore the actual gas supply pressure is 94 PSI + 30 PSI = 124 PSI.

The supply pressure to the timer of the 84T should be set high enough to make the relay stroke reliably. The timer supply pressure should be approximately 10 psi higher than the relay supply pressure.

METERING PUMPS

P N E U M A T I C P L U N G E R

Figure 1, LINC 84T Series Pump

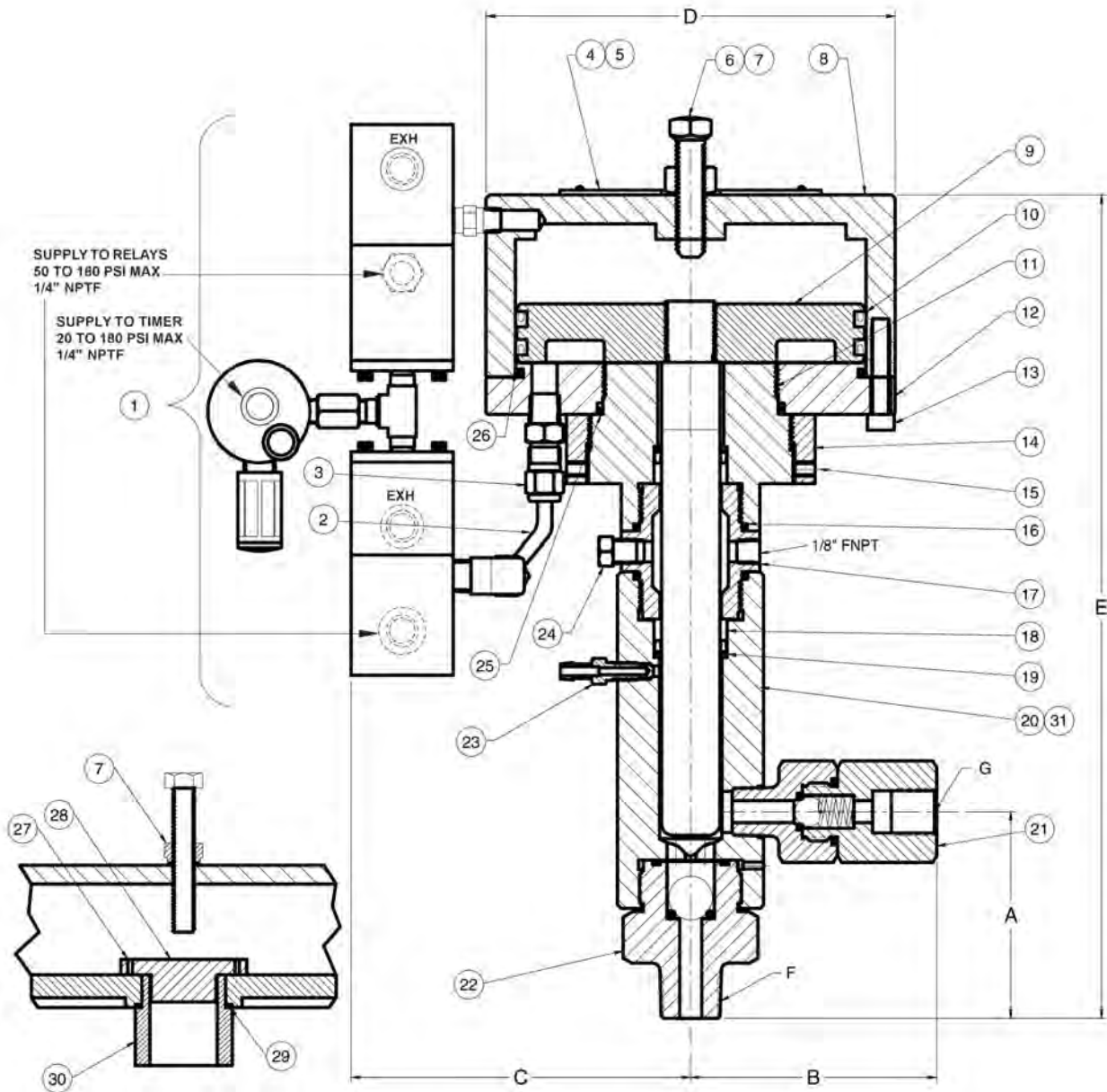

Model	84T-17-46	84T-17-48	84T-18-44	84T-18-46	84T-18-48	84T-20-46	84T-20-48	84T-20-410
A	3 1/2"	3 1/2"	5"	5"	4 7/8"	6 1/4"	6 1/4"	6 1/4"
B	4 1/4"	4 1/4"	4 7/8"	4 7/8"	4 3/4"	5 1/8"	5 1/8"	5 1/8"
C	6"	7"	5"	6"	7"	6"	7"	8"
D	7"	9"	5"	7"	9"	7"	9"	11"
E	14 5/8"	14 3/4"	13 5/8"	13 7/8"	14"	17 7/8"	17 7/8"	17 7/8"
F Suction	3/4" NPTM	3/4" NPTM	2" NPTM	2" NPTM	2" NPTM	2" NPTM	2" NPTM	2" NPTM
G Discharge	1/2" NPTF	1/2" NPTF	3/4" NPTF	3/4" NPTF	3/4" NPTF	3/4" NPTF	3/4" NPTF	3/4" NPTF

METERING PUMPS

P N E U M A T I C P L U N G E R

84T-17 Pump Assembly

Model	84T-17-X6	84T-17-X8
Plunger Size	1"	1"
Piston Size	6"	8"

Item	Part#	Part#	Description	Material	Qty
1	*31858	*31858	Timer/Relay Assembly	316 ss	1
2	18615	18615	Tubing	316 ss	1
3	12326	12326	Tube Fitting	316 ss	1
4	10289	10289	Nameplate	18-8 ss	1
5	10324	10324	Nameplate Drive Screw	18-8 ss	2
6	11843	11843	Stroke Adjustment Screw	18-8 ss	1
7	20985	20985	Sealing Jam Nut	18-8 ss	1
8	44249	43756	Piston Housing	303 ss	1
9	31407	44466	Piston/Plunger Assembly	17-4PH ss	1
10	13031	13032	Piston U-Cup	Nitrile	2
11	31391	31391	Center Housing Adapter	316 ss	1
12	44181	44467	Center Ring	303 ss	1
13	11795		Cap Screw	18-8 ss	6
13		11795	Cap Screw	18-8 ss	10
14	44186	44186	Center Housing Locknut	303 ss	1
15	12437	12437	Set Screw	18-8 ss	2
16	12693	12693	Center Housing O-ring	Nitrile	2
17	24404	24404	Center Body	303 ss	1
18	23551	23551	Plunger Seal Back Up	Acetal	2
19	11590	11590	Plunger Seal(84T-17-46,8)	TFE Graphite	2
19	11587	11587	Plunger Seal(84T-17-16,8)	Flourocarbon	2
19	13143	13143	Plunger Seal(84T-17-66,8)	UHMWPE	2
20	31749	31749	Lower Body	316 ss	1
21	25211	25211	Discharge Check Assembly	316 ss See parts Figure 6	1
22	25245	25245	Suction Check Assembly	316 ss See parts Figure 7	1
23	20460	20460	Bleed Screw	316 ss	1
24	10278	10278	Pipe Plug	304 ss	2
25	12428	12428	Center Ring O-Ring	Nitrile	2
26	13333	11798	Piston Housing O-Ring	Nitrile	1

*(Consist of P/N 31735-Timer, P/N 31856-Two Seal Single Acting Relay, and P/N 31686 Single Acting Relay)

METERING PUMPS

P N E U M A T I C P L U N G E R

84T-18 Pump Assembly

Model	84T-18-44	84T-18-46	84T-18-48
Plunger Size	1 1/2"	1 1/2"	1 1/2"
Piston Size	4"	6"	8"

Item	Part#	Part#	Part #	Description	Material	Qty
1	*31858	*31858	*31858	Timer/Relay Assembly	316 ss	1
2	18615	18615	18615	Tubing	316 ss	1
3	12326	12326	12326	Tube Fitting	316 ss	1
4	10289	10289	10289	Nameplate	18-8 ss	1
5	10324	10324	10324	Nameplate Drive Screw	18-8 ss	2
6	11843	11843	11843	Stroke Adjustment Screw	18-8 ss	1
7	20985	20985	20985	Sealing Jam Nut	18-8 ss	1
8	31295	43755	43756	Piston Housing	303 ss	1
9	31294			Piston	303 ss	1
9		31214	31209	Piston	6061 Al	1
10	12134			O-Ring	Nitrile	1
10a		13031	13032	Piston U-Cup	Nitrile	2
11	N/A	N/A	N/A	Center Housing Adapter		
12	N/A	N/A	N/A	Center Ring		
13	11795			Cap Screw	18-8 ss	6
13		11795	11795	Cap Screw	18-8 ss	8
14	Not Applicable on this pump					
15	Not Applicable on this pump					
16	11791	11791	11791	Center Housing O-Ring	Nitrile	2
17	Not Applicable on this pump					
18	23990	23990	23990	Plunger Seal Back Up	Acetal	2
19	11794	11794	11794	Plunger Seal	TFE/Graphite	2
19**	12981	12981	12981	Plunger Seal	UHMWPE	2
19	23990	23990	23990	Plunger Seal Backup	Acetal	2
20	Not Applicable on this pump					
21	24754	24754	24754	Discharge Check Assembly	See parts figure 6	1
22	31220	31220	31220	Suction Check Assembly	See parts figure 8	1
23	20460	20460	20460	Bleed Screw	316 ss	1
24	10278	10278	10278	Pipe Plug	304 ss	1
25	11578	11578	11578	Center Ring O-Ring	Nitrile	1
26	12137	12432	11798	Piston Housing O-Ring	Nitrile	1
27	12138	12138	11785	Set Screw	18-8 ss	1
28	Not Applicable on this pump					
29	Not Applicable on this pump					
30	24095	24095	24095	Plunger	17-4 PH ss	1
31	31297	43902	43760	Body Assembly	316 ss	1

*(Consist of P/N 31735-Timer, P/N 31856-Two Seal Single Acting Relay, and P/N 31686 Single Acting Relay)

** Pump Model Number becomes 84T-18-64, 66, 68

METERING PUMPS

P N E U M A T I C P L U N G E R

84T-20 Pump Assembly

Model	84T-20-46	84T-20-48	84T-20-410
Plunger Size	2 1/4"	2 1/4"	2 1/4"
Piston Size	6"	8"	10"

Item	Part#	Part#	Part #	Description	Material	Qty
1	*31858	*31858	*31858	Timer/Relay Assembly	316 ss	1
2	18615	18615	18615	Tubing	316 ss	1
3	12326	12326	12326	Tube Fitting	316 ss	1
4	10289	10289	10289	Nameplate	18-8 ss	1
5	10324	10324	10324	Nameplate Drive Screw	18-8 ss	2
6	12667	12667	24354	Stroke Adjustment Screw	18-8 ss	1
7	20985	20985	24356	Sealing Jam Nut	18-8 ss	1
8	44179	44419	51093	Piston Housing	303 ss	1
9	44180	44417	44189	Piston	6061 Al	1
10	13031	13032	13033	Piston U-Cup	Nitrile	2
11	44184	44184	44184	Center Housing Adapter	303 ss	1
12	44181	44418	44190	Center Ring	303 ss	1
13	11795			Cap Screw	18-8 ss	6
13		11795		Cap Screw	18-8 ss	8
13			11795	Cap Screw	18-8 ss	12
14	44186	44186	44186	Center Housing Locknut	303 ss	1
15	12437	12437	12437	Set Screw	18-8 ss	2
16	12428	12428	12428	Center Housing O-ring	Nitrile	3
17	44188	44188	44188	Center Body	303 ss	1
18	24304	24304	24304	Plunger Seal Backup	Acetal	2
19	12415	12415	12415	Plunger Seal	TFE/Graphite	2
20	44185	44185	44185	Lower Body	303 ss	1
21	24754	24754	24754	Discharge Check Assembly	See parts(fig.6)	1
22	31220	31220	31220	Suction Check Assembly	See parts(fig.8)	1
23	20460	20460	20460	Bleed Screw	316 ss	1
24	10278	10278	10278	Pipe Plug	304 ss	2
25	Not Applicable on this pump					
26	12432	12850	12430	Piston Housing O-Ring	Nitrile	1
27	12437	12437	12437	Set Screw	18-8 ss	5
28	31380	31380	31380	Plunger Cap	303 ss	1
28	12429	12429	12429	Piston Plunger O-Ring	Nitrile	1
30	44187	44187	44187	Plunger	17-4 PH ss	1

*(Consist of P/N 31735-Timer, P/N 31856-Two Seal Single Acting Relay, and P/N 31686 Single Acting Relay)

METERING PUMPS

P N E U M A T I C P L U N G E R

Figure 2, "T" Series Timer

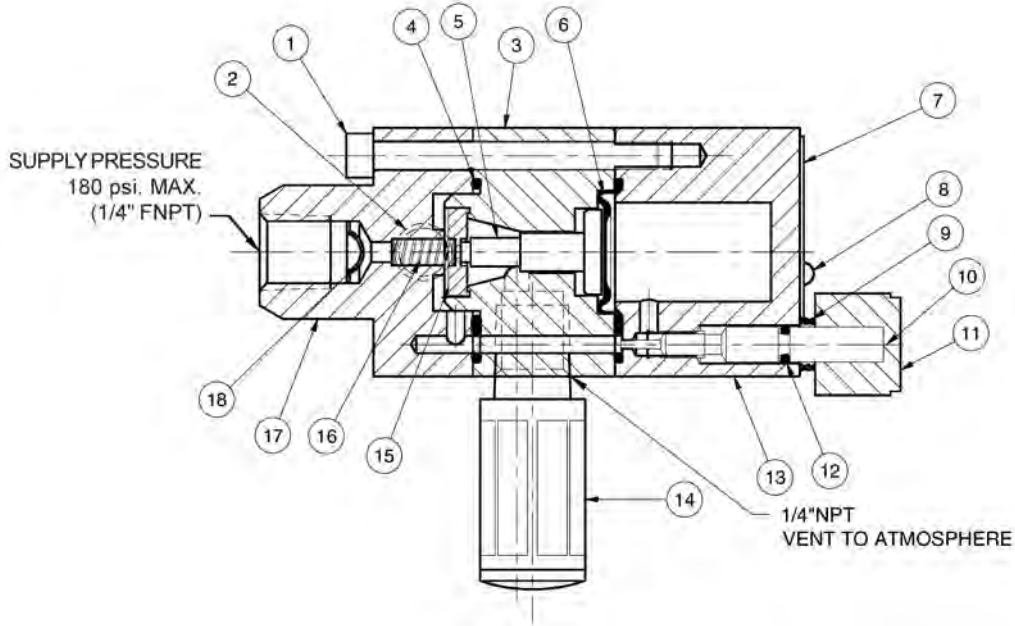

"T" Series Timer Parts List

Assembly: 31735

Item	Part #	Description	Material	Qty
1	13223	Screw	18-8 ss	2
2	25130	Hex Nipple	316 ss	1
3	31733	Center Body	316 ss	1
4*	13227	Seal	Nitrile	1
5*	13247	Disc Actuator	Delrin	1
6*	13226	Diaphragm	Nitrile	1
7	13246	Nameplate	18-8 ss	1
8	10324	Drive Screw	18-8 ss	2
9	13253	Knob Spring	Stainless Steel	1
10	25210	Adjustment Screw	316 ss	1
11	13243	Knob	Polycarbon	1
12	10326	O-ring	Nitrile	1
13	31732	Front Body	316 ss	1
14	12952	Muffler	Plastic	1
15*	13225	Disc	Aluminum / Nitrile	1
16*	13222	Disc Spring	Stainless Steel	1
17	31734	Rear Body	316 ss	1
18	10244	Screen	Stainless Steel	1
Not Shown	13233	Pin	Stainless Steel	3
*Not Shown	25183	Repair Kit	Recommended Spares for the "T" Series Timer	1

METERING PUMPS

P N E U M A T I C P L U N G E R

Figure 3, Double Acting Relay*

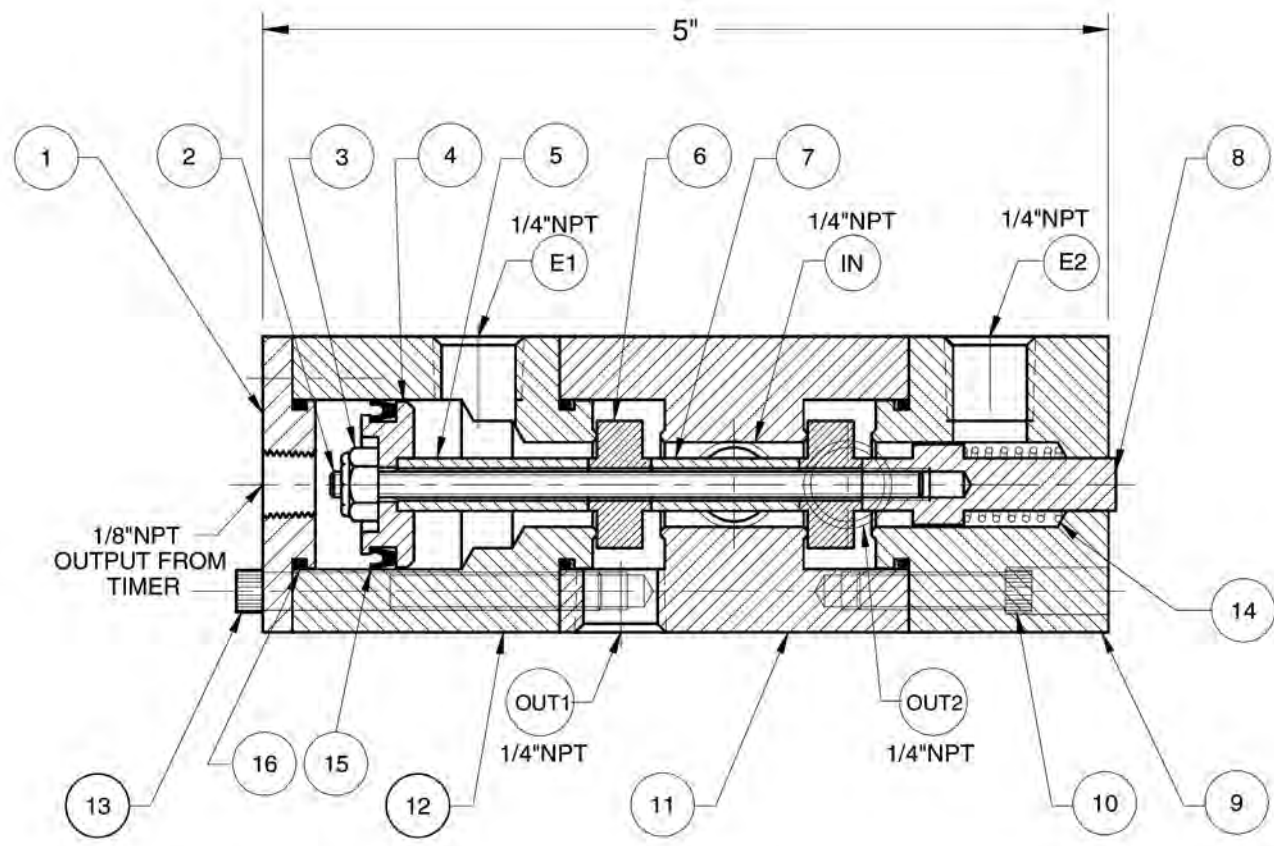

*Double Acting Relay for Pumps purchased prior to 9-01-2001

Assembly Item	31564 Part #	Double Acting Relay Assembly Description	Material	Qty
1	24823	Lid	316 ss	1
2	24825	Threaded Rod	303 ss	1
3	13078	Lock Nut	18-8 ss	1
4	24828	Piston	316 ss	1
5	24827	Piston Spacer	316 ss	1
6	24746	Seal Poppet	316 ss	2
7	24826	Seal Spacer	316 ss	1
8	24824	Spring Shaft	316 ss	1
9	31562	Lower Body	316 ss	1
10	13076	Screw	18-8 ss	1
11	31561	Middle Body	316 ss	1
12	31560	Upper Body	316 ss	1
13	13077	Screw	18-8 ss	1
14	13036	Spring	18-8 ss	1
15	12365	Piston Seal	Urethane	1
16	12364	O-Ring	Nitrile	1
-	24284	Repair Kit		1

METERING PUMPS

P N E U M A T I C P L U N G E R

Figure 4, Two Seal Single Acting Relay

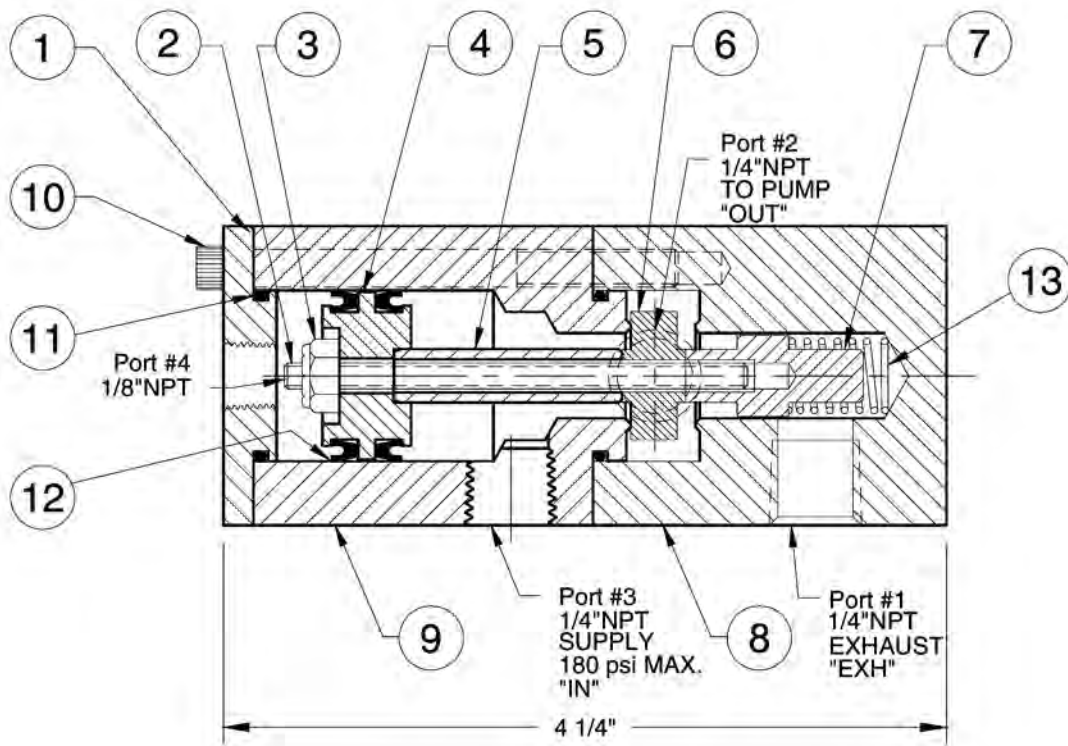

Assembly Item	31856 Part #	Two Seal Relay Assembly Description	Material	Qty
1	24823	Lid	316 ss	1
2	25415	Threaded Rod	18-8 ss	1
3	13078	Lock Nut	18-8 ss	1
4	25414	Piston	316 ss	1
5	25413	Piston Spacer	316 ss	1
6	24746	Seal Poppet	316 ss	1
7	24923	Spring Shaft	316 ss	1
8	31597	Lower Body	316 ss	1
9	31857	Upper Body	316 ss	1
10	13383	Cap Screw	18-8 ss	4
11	12364	O-Ring	Nitrile	2
12	12365	Piston Seal	Urethane	2
13	13036	Spring	18-8 ss	1
-	25418	Repair Kit		1

METERING PUMPS

P N E U M A T I C P L U N G E R

Figure 5, Single Acting Relay

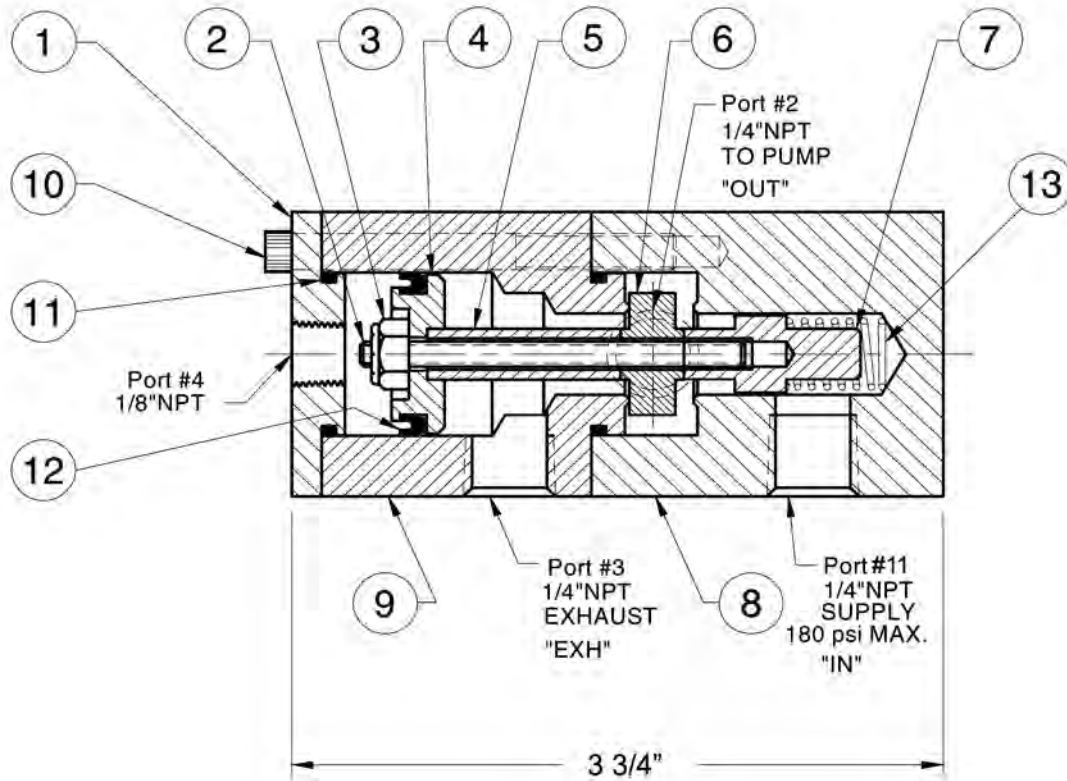

Assembly Item	Part #	Description	Material	Qty
1	24823	Lid	316 ss	1
2	25112	Threaded Rod	18-8 ss	1
3	13078	Lock Nut	18-8 ss	1
4	24828	Piston	316 ss	1
5	24827	Piston Spacer	316 ss	1
6	24746	Seal Poppet	316 ss	1
7	24923	Spring Shaft	316 ss	1
8	31597	Lower Body	316 ss	1
9	31560	Upper Body	316 ss	1
10	10193	Cap Screw	18-8 ss	4
11	12364	O-Ring	Nitrile	2
12	12365	Piston Seal	Urethane	1
13	13036	Spring	18-8 ss	1
-	25182	Repair Kit		1

METERING PUMPS

P N E U M A T I C P L U N G E R

Figure 6, Discharge Check Valve

Reference fig. 1, item 21

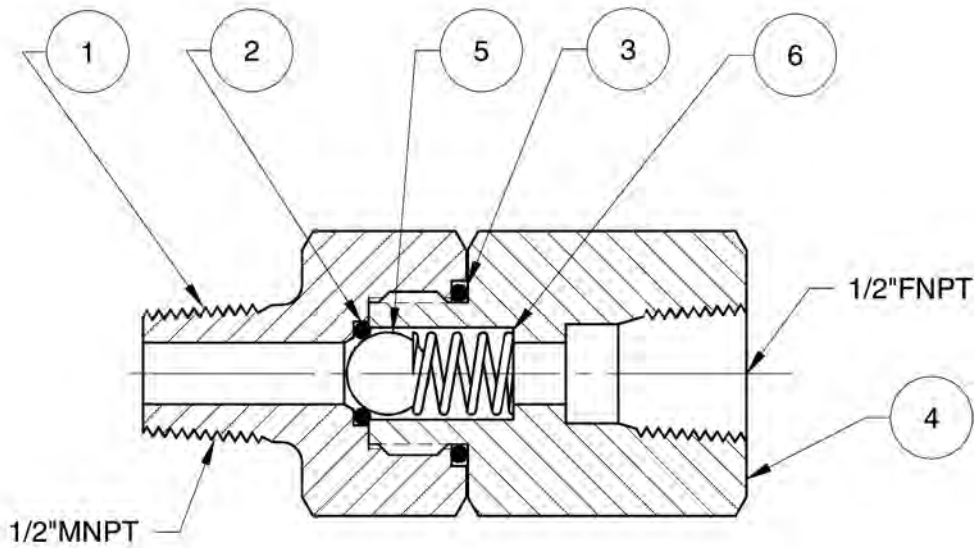

Discharge Check Valve - Two-Piece Body						
Assembly P/N:		24754	25211			
Port Size:		3/4" NPTF	1/2" NPTF			
Item	Part #	Part #	Description	Material	Qty	
1	23988	25204	Inlet Body	18-8 ss	1	
2	10314	10469	Seat	TFE	1	
3	10466	13113	Seal	Fluorocarbon	1	
4	24758	25205	Outlet Body	18-8 ss	1	
5		10529	Ball	Carbide	1	
5	12416		Ball	Carbide	1	
6		11604	Spring	316 ss	1	
6	11788		Spring	Inconel	1	

METERING PUMPS

P N E U M A T I C P L U N G E R

Figure 7, Suction Check Valve
Reference fig. 1, item 22

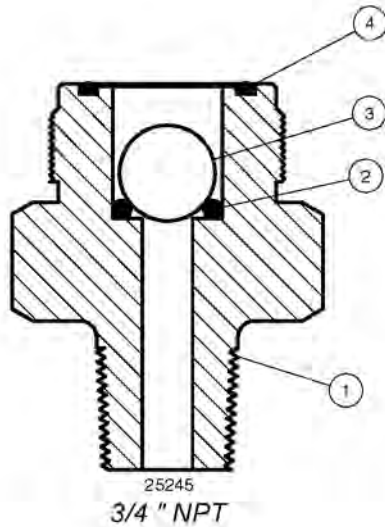
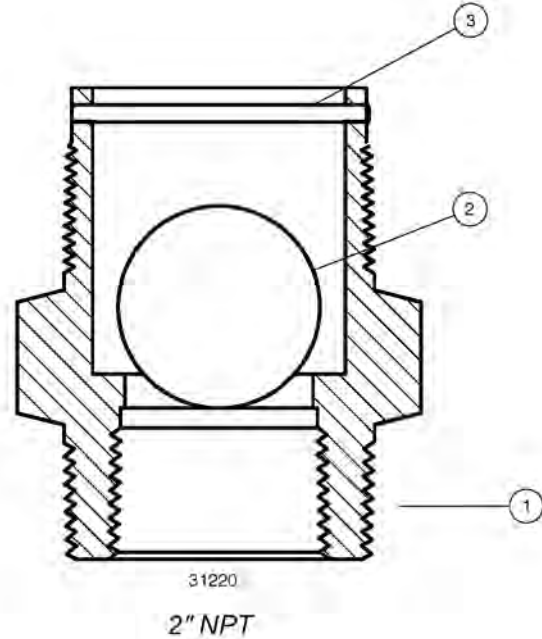

Figure 8, Suction Check Valve
Reference fig. 1, item 22



Suction Check Valve				
Assembly: 25245				
Item	Part #	Description	Material	Qty
1	31750	Inlet Body	316ss	1
2	11772	Seat	TFE	1
3	13115	Ball	Carbide	1
4	13271	Seal	TFE Encaps	1

Suction Check Valve - One - Piece Body				
Assembly: 31220				
Port Size: 3/4" NPT or 2" NPT				
Item	Part #	Description	Material	Qty
1	31273	Inlet Body	316ss	1
2	11789	Ball	440C ss	1
3	24010	Retainer	316ss	1

METERING PUMPS

LINC Chemical Pump Gas Consumption Table

ACTUATION PISTON DIA. (IN)>>	1.50	2.25	3	4	4	4	6	8	10
>> CONFIGURATION >>	SPRING RETURN NO RELAY	SPRING RETURN NO RELAY	SPRING RETURN NO RELAY	SPRING RETURN NO RELAY	SPRING RETURN INCLUDING RELAY	GAS RETURN INCLUDING RELAY	GAS RETURN INCLUDING RELAY	GAS RETURN INCLUDING RELAY	GAS RETURN INCLUDING RELAY
SUPPLY PRESS. (PSI)	VOLUME DISPLACED BY PISTON FOR 1" STROKE(CUBIC FEET)								
	0.00102265	0.00230097	0.00409062	0.00727221	0.00727221	0.01454441	0.03272492	0.05817764	0.09090257
	THEORETICAL GAS CONSUMPTION FOR EACH 1" STROKE (SCF)								
0	0.0000	0.0000	0.0000	0.0000	0.0000	0.0000	0.0000	0.0000	0.0000
10	0.0017	0.0039	0.0069	0.0122	0.0122	0.0244	0.0550	0.0978	0.1527
20	0.0024	0.0054	0.0097	0.0172	0.0172	0.0343	0.0772	0.1373	0.2146
30	0.0031	0.0070	0.0124	0.0221	0.0221	0.0442	0.0995	0.1769	0.2764
40	0.0038	0.0086	0.0152	0.0271	0.0271	0.0541	0.1218	0.2165	0.3383
50	0.0045	0.0101	0.0180	0.0320	0.0320	0.0640	0.1440	0.2561	0.4001
60	0.0052	0.0117	0.0208	0.0370	0.0370	0.0739	0.1663	0.2956	0.4619
70	0.0059	0.0133	0.0236	0.0419	0.0419	0.0838	0.1886	0.3352	0.5238
80	0.0066	0.0148	0.0264	0.0468	0.0468	0.0937	0.2108	0.3748	0.5856
90	0.0073	0.0164	0.0291	0.0518	0.0518	0.1036	0.2331	0.4144	0.6474
100	0.0080	0.0180	0.0319	0.0567	0.0567	0.1135	0.2553	0.4539	0.7093
110	0.0087	0.0195	0.0347	0.0617	0.0617	0.1234	0.2776	0.4935	0.7711
120	0.0094	0.0211	0.0375	0.0666	0.0666	0.1333	0.2999	0.5331	0.8330
130	0.0101	0.0226	0.0403	0.0716	0.0716	0.1432	0.3221	0.5727	0.8948
140	0.0108	0.0242	0.0430	0.0765	0.0765	0.1531	0.3444	0.6123	0.9566
150	0.0115	0.0258	0.0458	0.0815	0.0815	0.1630	0.3667	0.6518	1.0185



LINC Milton Roy represents and warrants that for a period of 3 years from receipt of the product: (1) the product will be free from defects in materials and workmanship; and (2) the product will perform substantially in accordance with product manuals, literature, or documentation. Any written or oral information or advice given by LINC Milton Roy representatives, agents, or employees will in no way increase the scope of this warranty. If the product fails to comply with the warranty set forth herein, LINC Milton Roy's entire liability and the customer's exclusive remedy will be replacement of the product(s) or, at LINC Milton Roy's option, LINC Milton Roy's reasonable effort to make the product meet the warranty set forth herein. **LINC Milton Roy disclaims all other warranties, either expressed or implied, including but not limited to, implied warranties or merchantability and fitness for a particular purpose, with respect to the product.** This limited warranty gives you specific legal rights. You may have others, which vary from state to state. **These remedies are not available outside of the United States and Canada.** In no event shall LINC Milton Roy or its suppliers be liable for any damages whatsoever (including, without limitation, damages for loss of profits, business interruption, loss of information, or other pecuniary loss) arising out of the use of or inability to use the product, even if LINC Milton Roy has been advised of the possibility of such damages. Information contained in this document is subject to change without notice and does not represent a commitment on the part of LINC Milton Roy. All prices quoted are in U.S. dollars, F.O.B. Ivyland, PA. LINC, LINC Chemical Pumps, and LINC Level & Flow Switches are trademarks of LINC Milton Roy. All other product names and/or registered trademarks are the property of their respective holders. LINC Milton Roy support services are subject to LINC Milton Roy's then-current prices, terms, and conditions, which are subject to change without notice. All prices and specifications, if published, are subject to change without notice.